



## **INFLATABLE BLOWERS OWNER'S MANUAL**

P-800I / P-800HI  
P-830I / P-830HI  
P-815I

XPOWER MANUFACTURE, INC.  
220 Clary Avenue  
San Gabriel, CA 91776, USA  
Tel: 626-285-3301, Fax: 626-285-3302  
[www.xpower.ws](http://www.xpower.ws)



PLEASE READ AND SAVE THESE INSTRUCTIONS

## Index

Introduction .....	2
Operation / Instructions.....	3
Safety Instructions.....	4
Maintenance Instructions / Troubleshooting.....	5
Specifications.....	6
Warranty / Service .....	7
Parts List .....	8
Accessories .....	9
Warranty Registration Form .....	10

## Introduction

XPOWER Inflatable Blowers are ETL/CETL Certified Professional Level Multifunctional Inflatable Blowers with the most efficient engineering design.

Features:

- Low power draw with a high velocity air flow from 3,200 to 3,600 CFM
- Quiet motor and lightweight.
- Easy carrying handle and stackable up to 3 units high.
- Easy and quick to disassemble for thorough cleaning and service.
- Power cord lengths are 20'.
- Easy cord wrap on handle.
- Luggage handle and wheels for "H" series models.
- Inflatable adapter for "I" series model
- Durable and rugged housing.
- Weather proof Indoor/Outdoor use with P-815I model.
- 3 airflow positions for "H" series models (0°, 20° Kickstand, 90°).
- 4 airflow positions for other models (0°, 20°, 45°, 90°).

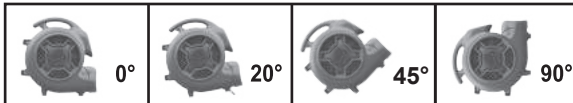

\* Except model P-815I

## Operation / Instructions

XPOWER Inflatable Blowers are intended to move air and to dry floors, walls, furniture, etc. Durable and easy to operate with an effective balance of static pressure and airflow, the units are suitable for a variety of applications.

1. Prior to plugging the unit into the power source, inspect completely for any shipping damage.
2. Adapter Assembly (Fig. A)
3. Plug the electrical cord into the power outlet.
4. Carefully place the Inflatable Blower unit on a stable, flat dry surface.
5. The unit is capable of being used at 4 different angles to direct air flow; unit with handle can be used at 3 different angles.
6. Turn the switch to select desired speed, while making sure unit operates normally.
7. All Inflatable Blowers in operation must be supervised at all times.



### **INFLATABLE BLOWER STORAGE**

Inflatable blowers can be stacked (up to 3) on their sides for storage.

**NOTICE:**  
Stacking feature is not secure for transportation.

**FIG. A**



**ADAPTER UNIT "I" FOR ALL  
INFLATABLE MODELS**

USE TO FOR INFLATABLE

## Safety Instructions

1. To prevent electric shock, do not operate the unit in standing water. Never plug in or unplug the unit with wet hands or while standing in water.
2. To avoid risk of injury, do not direct air flow at face or any part of body.
3. To reduce the risk of fire or electric shock, do not use the Inflatable Blower with any solid-state speed control device.
4. Use only with GFCI protected receptacles. Please contact a qualified electrician for verification and / or install GFCI receptacle if necessary.
5. Do not operate any Inflatable Blower with a damaged cord or plug. Discard the unit or return it to an authorized service facility for examination and/or repair.
6. Unplug the Inflatable Blower from the power supply before moving, servicing or cleaning.
7. Do not run the power cord under carpeting. Do not cover the power cord with throw rugs, runners, or similar coverings. Place the power cord away from traffic area to prevent tripping.
8. Do not allow children to play with or around an Inflatable Blower at any time.
9. Do not move or carry an Inflatable Blower while unit is operating.
10. All Inflatable Blowers in operation must be supervised at all times.

## Maintenance Instructions

- 1) To keep the Inflatable Blower clean, use a damp cloths to wipe the surface of the housing; do not immerse in liquid
- 2) When not in use, unplug and store the Inflatable Blower in a dry indoor place out of reach of children.
- 3) Always disconnect the Inflatable Blower from its source before performing any maintenance or cleaning.

## Troubleshooting

For any problems not listed below, call your local distributor or contact our Service Department.

PROBLEM	POSSIBLE CAUSE	SOLUTION
Inflatable Blower not running	No power input	Plug in the Inflatable Blower; check circuit breaker
	Switch not turned on	Turn on switch
	Inflatable Blower fan wheel jammed	Remove material jamming fan wheel
	Intake or exhaust blocked	Turn unit off and allow to cool, then remove blockage
Inflatable Blower vibrates	Accumulation of dirt on fan blades	Clean Inflatable Blower fan blades

## Specifications

<b>Model</b>	<b>P-800I</b>	<b>P-800HI</b>	<b>P-830I</b>	<b>P-830HI</b>	<b>P-815I</b>
<b>Volt/Frequency</b>	115V,60Hz	115V,60Hz	115V,60Hz	115V,60Hz	115V,60Hz
<b>Power</b>	3/4 HP	3/4 HP	1 HP	1 HP	1 HP
<b>Amps</b>	7.5	7.5	8.5	8.5	8
<b>Unit Weights</b>	24.2 Lbs.	27.2 Lbs.	25.2 Lbs.	28.2 Lbs.	26.1 Lbs.
<b>Speeds</b>	Three	Three	Three	Three	One
<b>Size (WxDxH) (Inch)</b>	17.5" x 21" x 18.5"	17.5" x 21" x 18.5"	17.5" x 21" x 18.5"	17.5" x 21" x 18.5"	17.5" x 21" x 18.5"
<b>Handle/Wheels Optional</b>	Optional		Optional		Optional
<b>Filter Optional</b>	Optional	Optional	Optional	Optional	Optional
<b>Cord Length</b>	20 Ft.	20 Ft.	20 Ft.	20 Ft.	20 Ft.
<b>Overheating Protecting</b>	Thermally Protecting	Thermally Protecting	Thermally Protecting	Thermally Protecting	Thermally Protecting
<b>Rated Airflow (on high)</b>	3200	3200	3600	3600	3600
<b>Housing</b>	PP	PP	PP	PP	PP
<b>Certification</b>	ETL/CETL	ETL/CETL	ETL/CETL	ETL/CETL	

## XPOWER LIMITED WARRANTY

XPOWER Warranty covers the unit from defects in materials and craftsmanship. The Warranty covers normal use for a term of one year from the original date of purchase including parts, labor and one way shipping. The XPOWER inflatable blower Housing and handle are covered for a term of five years from the date of original purchase.

### **Important !**

This Warranty does not cover signs of misuse including, but not limited to, a unit that has been dropped, subjected to water damage, tampering, improper voltage use or unauthorized maintenance and repairs. The power cord is not covered by the warranty.

### Service

In order to receive service or replacement parts under warranty, you must:

- A. Call Service Department for a Return Merchandise Authorization (RMA) number and to obtain return shipping instructions.
- B. Provide original proof of purchase.
- C. Use original non-damaged packaging or industrial certified packaging materials.

The end user will be responsible for shipping the unit (with the RMA number displayed on the shipping label) to the XPOWER Service Department. Upon inspection, XPOWER will advise you of the repairs needed and the cost (if applicable). XPOWER will provide repair or replacement parts depending on warranty



## 800 Series Parts List

Item No.	Parts Name	Item No.	Parts Name
800-1	Left Housing	800-2	Grid Cover (Motor Side)
800-3	Timer & Switch Plate	800-4-1/2	Switch Knob & Timer Knob
800-5	Switch	800-6	Motor
800-7	Right Housing	800-8	Power Cord
800-9	Fan	800-10	Grid Cover (Fan Side)
800-11	Air Outlet Grid Cover	800-12	Kick Stand
800-13	Rubber Feet (Not Shown)	800-14	Screws and Nuts (Not Shown)
800-15	Capacitor	800-16	Filters

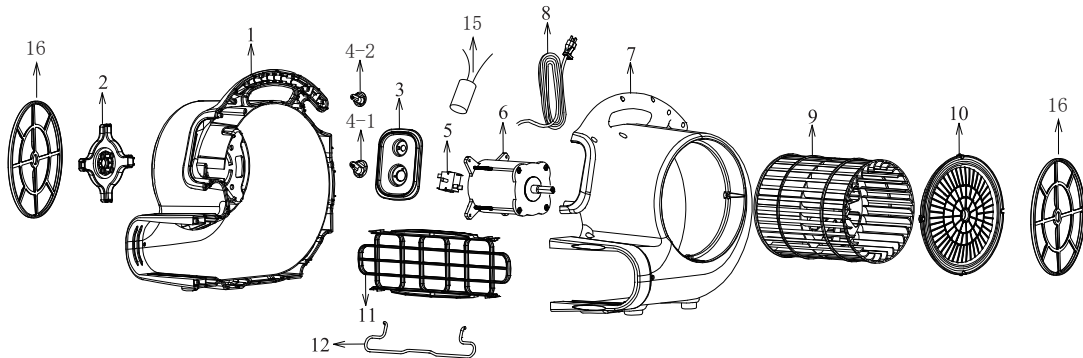

## Accessories

### Luggage Handle & Wheels

XPOWER Inflatable Blower Models P-800HI and P-830HI come with built-in extendable luggage handle and wheels for easy transportation and mobility.

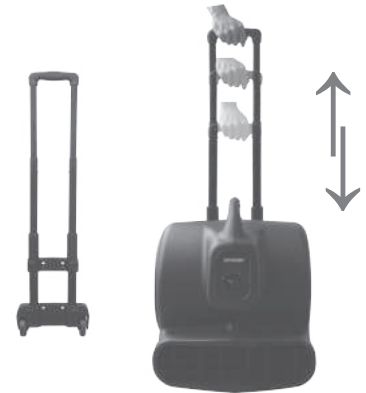

**FIG. A**



**ADAPTER UNIT "I" FOR ALL INFLATABLE MODELS**

### Filters (Optional)

A set of Filters is available for the Air Mover models which will help prevent small debris and dust from entering the unit. To clean the filters: Remove the filters from the unit and wash with warm soapy water, rinse with clean water and let dry thoroughly before reinstalling.

**Installation:**  
Filters snaps into the air inlets.

**Note:**  
The filter I is for Motor Side,  
The filter II is for Fan Side



**Filter Removal:**  
Pull the filters off the unit.

**Note:**  
After cleaning make sure the filters are dry before reinstalling.



# WARRANTY REGISTRATION

Please complete and mail or fax for your product warranty. For a multiple units, please list serial numbers on a separate sheet of paper. Address: XPOWER MANUFACTURE, INC, 220 Clary Avenue San Gabriel, CA 91776, USA  
Tel: (626) 285-3301; Fax: (626) 285-3302

Company Name / Contact Person / Title \_\_\_\_\_

Address \_\_\_\_\_ City \_\_\_\_\_

State / Province \_\_\_\_\_ Zip \_\_\_\_\_ Country \_\_\_\_\_

Phone \_\_\_\_\_ Fax \_\_\_\_\_ E-mail \_\_\_\_\_

**Model #** \_\_\_\_\_ **Serial #:** \_\_\_\_\_

**Date of Purchase** \_\_\_\_ / \_\_\_\_ / \_\_\_\_ **Purchased From** \_\_\_\_\_

**Additional Comments / Suggestions** \_\_\_\_\_



From: \_\_\_\_\_  
\_\_\_\_\_  
\_\_\_\_\_

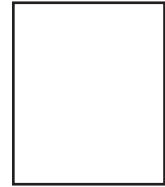

TO:  
XPOWER MANUFACTURE, INC.  
220 Clary Avenue  
San Gabriel, CA 91776, USA  
Tel: 626-285-3301, Fax: 626-285-3302





## INFLATABLE BLOWERS OWNER'S MANUAL

P-800I / P-800HI  
P-830I / P-830HI  
P-815I

XPOWER MANUFACTURE, INC.  
220 Clary Avenue  
San Gabriel, CA 91776, USA  
Tel: 626-285-3301, Fax: 626-285-3302  
www.xpower.ws



PLEASE READ AND SAVE THESE INSTRUCTIONS

### Introduction

XPOWER Inflatable Blowers are ETL/CETL Certified Professional Level Multifunctional Inflatable Blowers with the most efficient engineering design.

#### Features:

- Low power draw with a high velocity air flow from 3,200 to 3,600 CFM
- Quiet motor and lightweight.
- Easy carrying handle and stackable up to 3 units high.
- Easy and quick to disassemble for thorough cleaning and service.
- Power cord lengths are 20'.
- Easy cord wrap on handle.
- Luggage handle and wheels for "H" series models.
- Inflatable adapter for "I" series model
- Durable and rugged housing.
- Weather proof Indoor/Outdoor use with P-815I model.
- 3 airflow positions for "H" series models (0°, 20° Kickstand, 90°).
- 4 airflow positions for other models (0°, 20°, 45°, 90°).

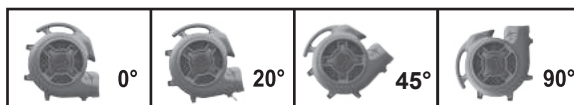

\* Except model P-815I

## Index

Introduction .....	2
Operation / Instructions.....	3
Safety Instructions.....	4
Maintenance Instructions / Troubleshooting.....	5
Specifications.....	6
Warranty / Service .....	7
Parts List .....	8
Accessories .....	9
Warranty Registration Form .....	10

## Operation / Instructions

XPOWER Inflatable Blowers are intended to move air and to dry floors, walls, furniture, etc. Durable and easy to operate with an effective balance of static pressure and airflow, the units are suitable for a variety of applications.

1. Prior to plugging the unit into the power source, inspect completely for any shipping damage.
2. Adapter Assembly (Fig. A)
3. Plug the electrical cord into the power outlet.
4. Carefully place the Inflatable Blower unit on a stable, flat dry surface.
5. The unit is capable of being used at 4 different angles to direct air flow; unit with handle can be used at 3 different angles.
6. Turn the switch to select desired speed, while making sure unit operates normally.
7. All Inflatable Blowers in operation must be supervised at all times.



### **INFLATABLE BLOWER STORAGE**

Inflatable blowers can be stacked (up to 3) on their sides for storage.

**NOTICE:**  
Stacking feature is not secure for transportation.

**FIG. A**



### **ADAPTER UNIT "I" FOR ALL INFLATABLE MODELS**

USE TO FOR INFLATABLE

## Safety Instructions

1. To prevent electric shock, do not operate the unit in standing water. Never plug in or unplug the unit with wet hands or while standing in water.
2. To avoid risk of injury, do not direct air flow at face or any part of body.
3. To reduce the risk of fire or electric shock, do not use the Inflatable Blower with any solid-state speed control device.
4. Use only with GFCI protected receptacles. Please contact a qualified electrician for verification and / or install GFCI receptacle if necessary.
5. Do not operate any Inflatable Blower with a damaged cord or plug. Discard the unit or return it to an authorized service facility for examination and/or repair.
6. Unplug the Inflatable Blower from the power supply before moving, servicing or cleaning.
7. Do not run the power cord under carpeting. Do not cover the power cord with throw rugs, runners, or similar coverings. Place the power cord away from traffic area to prevent tripping.
8. Do not allow children to play with or around an Inflatable Blower at any time.
9. Do not move or carry an Inflatable Blower while unit is operating.
10. All Inflatable Blowers in operation must be supervised at all times.

- 4 -

## Specifications

<b>Model</b>	<b>P-800I</b>	<b>P-800HI</b>	<b>P-830I</b>	<b>P-830HI</b>	<b>P-815I</b>
<b>Volt/Frequency</b>	115V,60Hz	115V,60Hz	115V,60Hz	115V,60Hz	115V,60Hz
<b>Power</b>	3/4 HP	3/4 HP	1 HP	1 HP	1 HP
<b>Amps</b>	7.5	7.5	8.5	8.5	8
<b>Unit Weights</b>	24.2 Lbs.	27.2 Lbs.	25.2 Lbs.	28.2 Lbs.	26.1 Lbs.
<b>Speeds</b>	Three	Three	Three	Three	One
<b>Size (WxDxH) (Inch)</b>	17.5" x 21" x 18.5"	17.5" x 21" x 18.5"	17.5" x 21" x 18.5"	17.5" x 21" x 18.5"	17.5" x 21" x 18.5"
<b>Handle/Wheels Optional</b>	Optional		Optional		Optional
<b>Filter Optional</b>	Optional	Optional	Optional	Optional	Optional
<b>Cord Length</b>	20 Ft.	20 Ft.	20 Ft.	20 Ft.	20 Ft.
<b>Overheating Protecting</b>	Thermally Protecting	Thermally Protecting	Thermally Protecting	Thermally Protecting	Thermally Protecting
<b>Rated Airflow (on high)</b>	3200	3200	3600	3600	3600
<b>Housing</b>	PP	PP	PP	PP	PP
<b>Certification</b>	ETL/CETL	ETL/CETL	ETL/CETL	ETL/CETL	

- 6 -

## Maintenance Instructions

- 1) To keep the Inflatable Blower clean, use a damp cloths to wipe the surface of the housing; do not immerse in liquid
- 2) When not in use, unplug and store the Inflatable Blower in a dry indoor place out of reach of children.
- 3) Always disconnect the Inflatable Blower from its source before performing any maintenance or cleaning.

## Troubleshooting

For any problems not listed below, call your local distributor or contact our Service Department.

PROBLEM	POSSIBLE CAUSE	SOLUTION
Inflatable Blower not running	No power input	Plug in the Inflatable Blower; check circuit breaker
	Switch not turned on	Turn on switch
	Inflatable Blower fan wheel jammed	Remove material jamming fan wheel
	Intake or exhaust blocked	Turn unit off and allow to cool, then remove blockage
Inflatable Blower vibrates	Accumulation of dirt on fan blades	Clean Inflatable Blower fan blades

- 5 -

## XPOWER LIMITED WARRANTY

XPOWER Warranty covers the unit from defects in materials and craftsmanship. The Warranty covers normal use for a term of one year from the original date of purchase including parts, labor and one way shipping. The XPOWER inflatable blower Housing and handle are covered for a term of five years from the date of original purchase.

### **Important !**

This Warranty does not cover signs of misuse including, but not limited to, a unit that has been dropped, subjected to water damage, tampering, improper voltage use or unauthorized maintenance and repairs. The power cordd is not covered by the warranty.

### Service

In order to receive service or replacement parts under warranty, you must:

- A. Call Service Department for a Return Merchandise Authorization (RMA) number and to obtain return shipping instructions.
- B. Provide original proof of purchase.
- C. Use original non-damaged packaging or industrial certified packaging materials.

The end user will be responsible for shipping the unit (with the RMA number displayed on the shipping label) to the XPOWER Service Department. Upon inspection, XPOWER will advise you of the repairs needed and the cost (if applicable). XPOWER will provide repair or replacement parts depending on warranty

- 7 -



## 800 Series Parts List

Item No.	Parts Name	Item No.	Parts Name
800-1	Left Housing	800-2	Grid Cover (Motor Side)
800-3	Timer & Switch Plate	800-4-1/2	Switch Knob & Timer Knob
800-5	Switch	800-6	Motor
800-7	Right Housing	800-8	Power Cord
800-9	Fan	800-10	Grid Cover (Fan Side)
800-11	Air Outlet Grid Cover	800-12	Kick Stand
800-13	Rubber Feet (Not Shown)	800-14	Screws and Nuts (Not Shown)
800-15	Capacitor	800-16	Filters

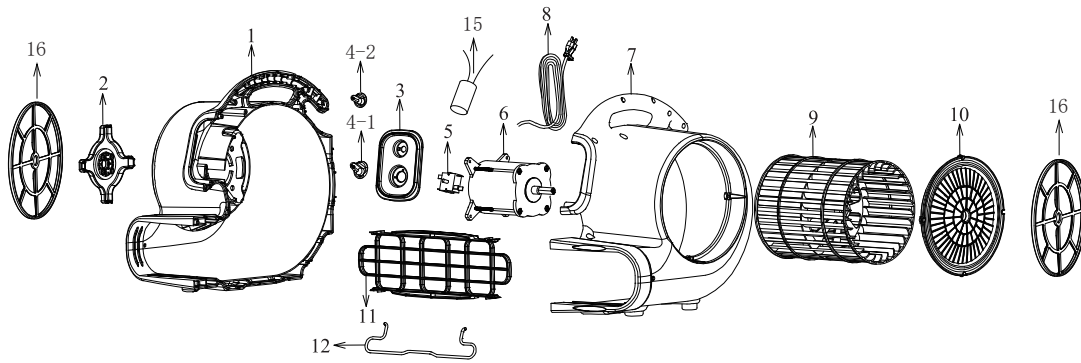

- 8 -

## WARRANTY REGISTRATION

Please complete and mail or fax for your product warranty. For a multiple units, please list serial numbers on a separate sheet of paper. Address: XPOWER MANUFACTURE, INC, 220 Clary Avenue San Gabriel, CA 91776, USA  
Tel: (626) 285-3301; Fax: (626) 285-3302

Company Name / Contact Person / Title \_\_\_\_\_

Address \_\_\_\_\_ City \_\_\_\_\_

State / Province \_\_\_\_\_ Zip \_\_\_\_\_ Country \_\_\_\_\_

Phone \_\_\_\_\_ Fax \_\_\_\_\_ E-mail \_\_\_\_\_

Model # \_\_\_\_\_ Serial #: \_\_\_\_\_

Date of Purchase \_\_\_\_/\_\_\_\_/\_\_\_\_ Purchased From \_\_\_\_\_

Additional Comments / Suggestions \_\_\_\_\_



## Accessories

### Luggage Handle & Wheels

XPOWER Inflatable Blower Models P-800HI and P-830HI come with built-in extendable luggage handle and wheels for easy transportation and mobility.

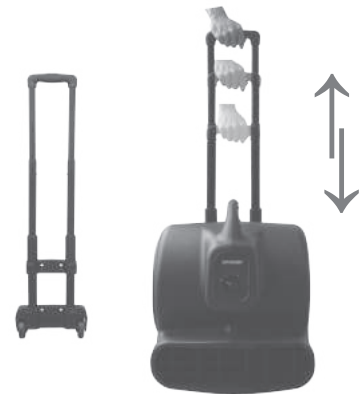

FIG. A



ADAPTER UNIT "I" FOR ALL INFLATABLE MODELS

### Filters (Optional)

A set of Filters is available for the Air Mover models which will help prevent small debris and dust from entering the unit. To clean the filters: Remove the filters from the unit and wash with warm soapy water, rinse with clean water and let dry thoroughly before reinstalling.

#### Installation:

Filters snaps into the air inlets.

#### Note:

The filter I is for Motor Side,  
The filter II is for Fan Side



#### Filter Removal:

Pull the filters off the unit.

#### Note:

After cleaning make sure the filters are dry before reinstalling.



- 9 -

From: \_\_\_\_\_  
\_\_\_\_\_  
\_\_\_\_\_

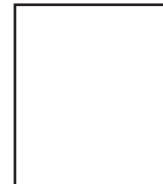

TO:

XPOWER MANUFACTURE, INC.

220 Clary Avenue

San Gabriel, CA 91776, USA

Tel: 626-285-3301, Fax: 626-285-3302

